

ASPHERIC COEFFICIENTS

	R	k	A4
S1	6.277	-0.6139	6.8E-05
S2	PLANO	-	-

$$z = \frac{Y^2}{R(1 + \sqrt{1 - (1 + k)Y^2/R^2})} + A_4Y^4$$

ASPHERIC LENS EQUATION

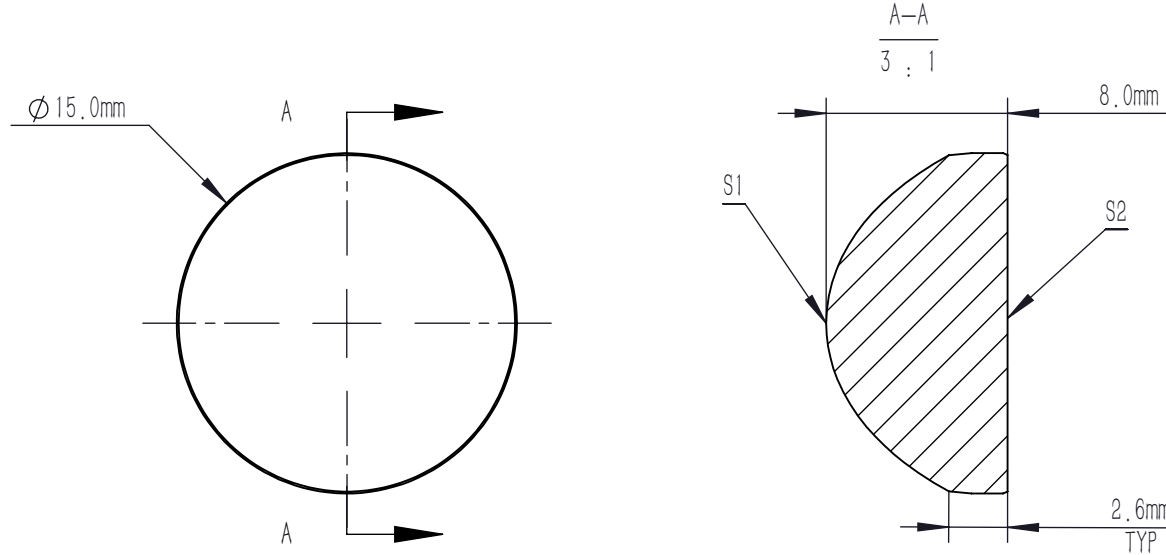

NOTES

1. MATERIAL: B270
2. DESIGN WAVELENGTH: 633.0 nm
3. WORKING WAVELENGTH: 380 nm-2100 nm
4. NUMERICAL APERTURE: 0.61
5. F/#: 0.89
6. FOCAL LENGTH: 12.0 mm
7. FOCAL LENGTH TOLERANCE: ±8%
8. BACK FOCAL LENGTH(REF): bf=7.0 mm
9. CLEAR APERTURE: >90%CA
10. DIAMETER TOLERANCE: +0.0/-0.5 mm
11. THICKNESS TOLERANCE: ±0.3 mm
12. CHAMFER: 0.2 mm, 45°
13. SURFACE QUALITY: 80-50 SCRATCH-DIG
14. CENTRATION: <30 arcmin
15. MAXIMUM TEMPERATURE: 250°C(482°F)
16. COATING: WHITOUT AR COATING

DRAWING PROJECTION						
			ASL1512			
DRAWN	WENSHUO	2024/08/28	Ø 15.0 mm, F=12.0 mm, NA=0.61 ASPHERIC CONDENSER LENS UNCOATED			
APPROVAL	SHAWN	2024/08/28	MATERIAL	WEIGHT	SCALE	REV
FOR INFORMATION ONLY NOT FOR MANUFACTURING PURPOSES			B270		5:1	A